

Erklärung Symbole

Explanation Symbols

	<u>Artikelnummer</u> material number		<u>Einschaltstrom</u> inrush current
	<u>Abmaße</u> dimensions		<u>Leitungsschutzschalter B10</u> circuit breaker B10
	<u>Größe Deckenausschnitt</u> ceiling cutout		<u>Leitungsschutzschalter B16</u> circuit breaker B16
	<u>Gewicht</u> weight		<u>Leitungsschutzschalter C10</u> circuit breaker C10
	<u>Erkennungsweite</u> viewing distance		<u>Leitungsschutzschalter C16</u> circuit breaker C16
	<u>Nennlampe (Art)</u> lamp (type)		<u>Energieeffizienzklasse Leuchte</u> energy efficiency class lighting
	<u>Leistung Nennlampe</u> power lamp		<u>Energieeffizienzklasse LED</u> energy efficiency class LED
	<u>Leistung Zusatzlampe</u> power extra lamp		<u>Energieeffizienzklasse Glühlampe</u> energy efficiency class light bulb
	<u>Systemleistung</u> system power		<u>Pollerleuchte</u> Bollards
	<u>Systemleistung Notbetrieb</u> system power emergency mode		<u>Deckenleuchte</u> ceiling luminaires
	<u>Farbwiedergabeindex (Ra)</u> colour rendering index (Ra)		<u>Wandleuchte</u> wall luminaires
	<u>Lichtfarbe</u> light colour		<u>Pendelleuchte</u> Pendant luminaires
	<u>Leuchtenlichtstrom</u> luminous flux		<u>Bodeneinbauleuchte</u> In-ground luminaires
	<u>Leuchtenlichtstrom Notbetrieb</u> luminous flux emergency mode		<u>Mastaufsatzleuchte</u> Pole top luminaires
	<u>Vor Wartung oder Reparatur spannungsfrei schalten</u> power off before maintenance or repair		<u>Deckeneinbauleuchte</u> Recessed ceiling luminaires
	<u>Ersatzartikel</u> substitute		<u>Anbaustrahler</u> Surface mounted projectors
	<u>Zubehör</u> Accessories		

INSTRUCTION

Stoffschirme und Abdeckscheiben für Toledo Flat Square

CE

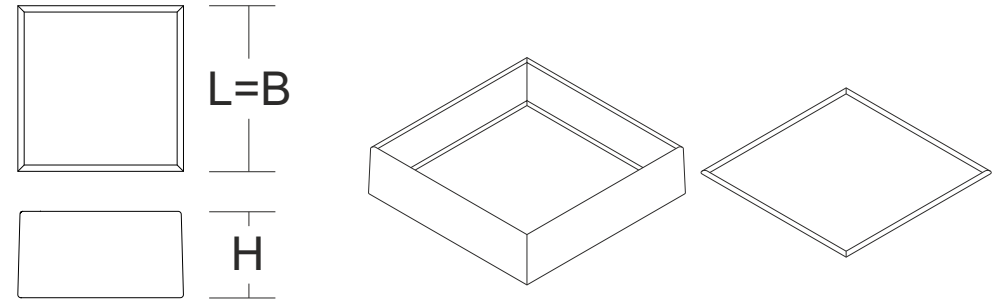

	982501.XXX 982502.XXX 982503.XXX 982504.XXX	L 115, B 115, H 60 L 177, B 177, H 60 L 230, B 230, H 60 L 305, B 305, H 60	65 g 102 g 134 g 178 g	! XXX - Farbcode
	982505.XXX 982506.XXX 982507.XXX 982508.XXX	L 113, B 113, H 4 L 175, B 175, H 4 L 228, B 228, H 4 L 303, B 303, H 4	30 g 52 g 73 g 103 g	



RZB
Rudolf Zimmermann,
Bamberg GmbH
Rheinstraße 16
D-96052 Bamberg
Deutschland
Telefon +49 951/79 09-0
Telefax +49 951/79 09-198
www.rzb.de
info@rzb-leuchten.de

